User Manual

Wind Direction Sensor

RS485 Output

Ver1.0



Chapter 1: Introduction

1.1. Overview

Our Wind Direction Sensor with RS485 digital output is compact and light in shape, easy to carry and assemble. The three-cup design concept can effectively obtain the information of the external environment. The shell is made of high quality polycarbon, and the outside is electroplated and sprayed. at the same time with the internal smooth bearing system, to ensure the accuracy of information collection. It is widely used in wind direction measurement of greenhouses, environmental protection, weather stations, ships, docks and aquaculture.

1.2. Main Parameters

Parameters	Index
Measure Range Of Direction	0-360°
Accuracy Of Direction	±3°
Response Time	<5s
Baud Rate	9600
Communication Port	Digital RS485
Power Supply	12V-24V DC
Power Consumption	<1W
Working Temperature	-30-80°C

1.3. System Topology

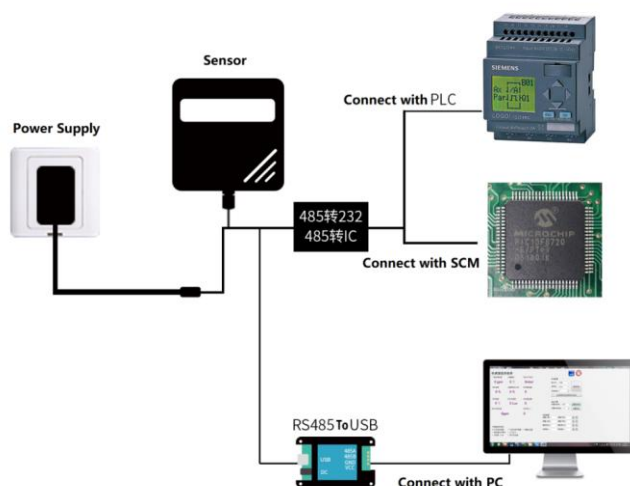

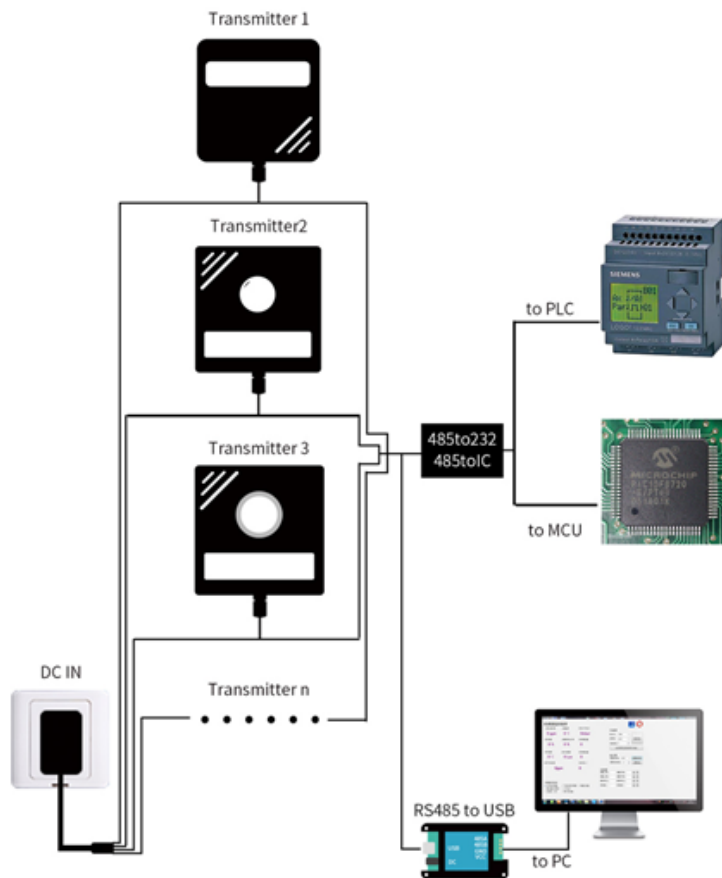

Chapter 2: Installation Instructions

2.1. Packaging Contents

Contents	Quantity
Sensor Device	1 set
RS485 Cable	1 set
12V Waterproof Power Source	1 set(optional)
USB TO RS485 Converter	1 set (optional)
Warranty Card & Qualification Certificate	1 set

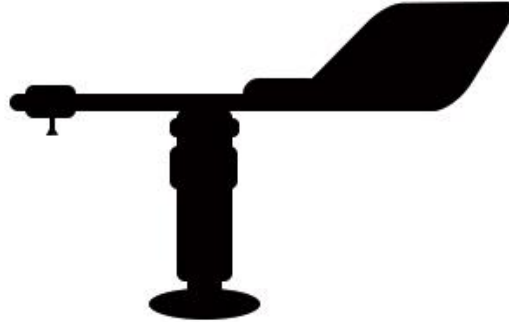

2.2. Installation of Cables

Cables	Colors	Index
Power	Red	Positive
	Black	Negative
Communication	yellow	485+
	Green	485 -

We provide 0.6M RS485 communicate cable by default. You can extend the cable as needed or connect the cables in sequence.

2.3. Device Installation

Adopt flange installation, threaded flange connection that the lower part of the wind sensor fitting firmly fixed in the flange plate, chassis on the circumference of the four Φ 6 mm mounting holes, using bolts should be firmly fixed to the bracket, to keep a complete set of equipment at the best level, ensure the accuracy of the wind data, flange connection is convenient to use, can withstand greater pressure.

Note: When the sensor is installed, the base has the letter N, which is facing the north.

2.3.1 Fixed Method

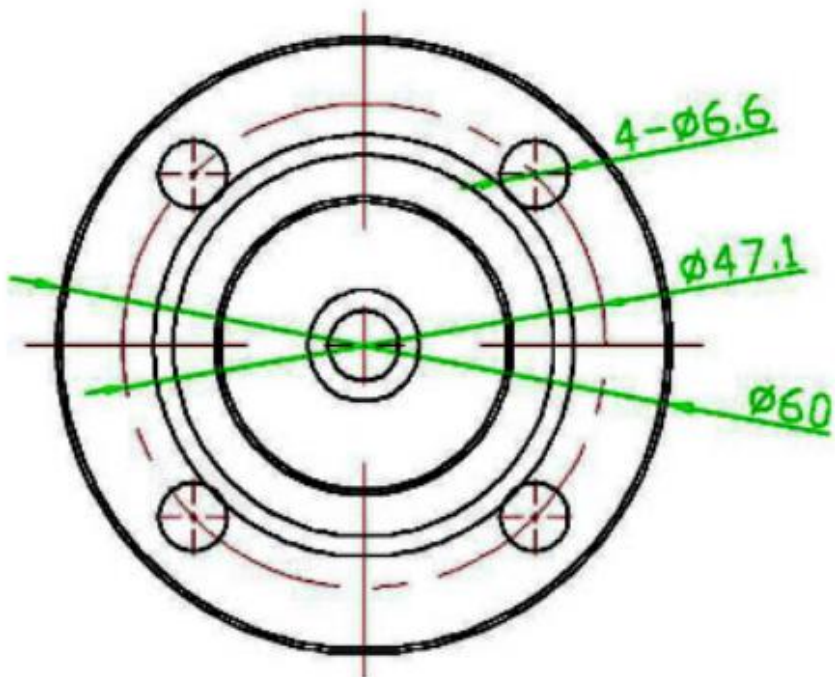
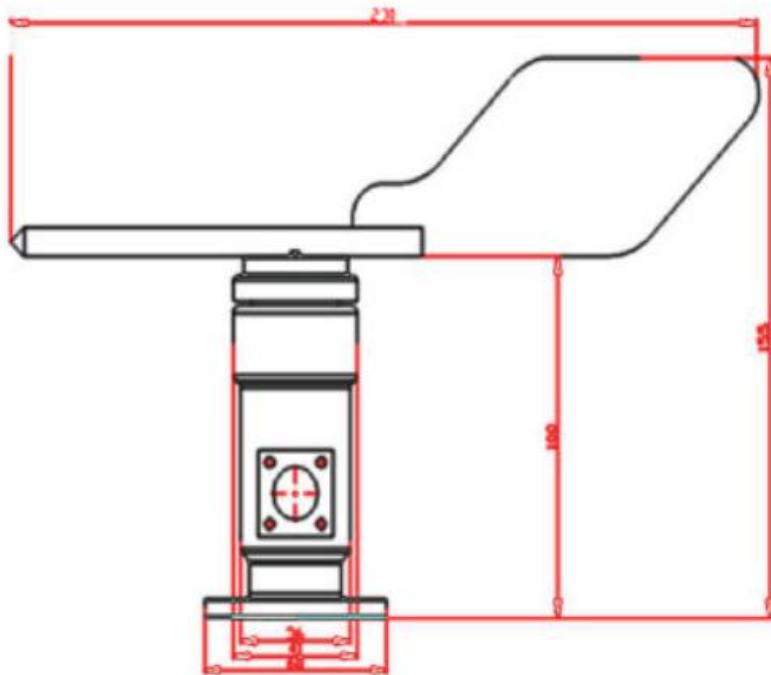

Chapter 3: Communication Protocol

3.1. Basic Communication Parameters

Parameters	Contents
Code	8bits Binary

Date Bit	8bit		
Parity Bit	None		
Stop Bit	1bit		
Error Calibration	CRC Long loop code		
Baud Rate	2400bps/4800bps/9600 [Default:9600bps]	bps	Optional

3.2.Data Frame Format Definition

Modbus-rtu communication protocol is adopted as follows:

The initial structure ≥ 4 bytes of time

Address code = 1 byte

Function code = 1 byte

Data area = N bytes

Error check = 16 bit CRC code

The time to end the structure ≥ 4 bytes

Address code: the address of the transmitter, which is unique in the polling network (factory default 0x01).

Function code: the instruction sent by the host indicates that the transmitter only USES the function code 0x03 (reads the memory data).

Data area: the data area is the specific query number area. Note that 16bits of data are in the first high byte

CRC code: two-byte check code.

Request Frame

Address	Function	Register	Origin	Length	Check Code Low Order	Check Code High Order
1byte	1byte	2bytes		2bytes	1byte	1byte

Response Frame

Address	Function	Effective byte	Date 1	Date 2	Date N
1byte	1byte	1byte	2bytes	2bytes	2bytes

3.3. Register Address

Address	PLC Config Add.	Contents	Opera.
0000H	40001	Wind Direction (Unit:1°)	Only R.
0100H	40101	Device Add.(0-252)	R.&W.
0101H	40102	Baud(2400/4800/9600)	R.&W.

3.4. Sample communication protocol and explanation

3.4.1. Read 0x01 Wind Direction Of Device Address

Request Frame						
Address	Function	Register	Origen	Length	Check Code	Check Code
0x02	0x03	0x00,0x00		0x00,0x01	Low Order 0x84	High Order 0x39
Response Frame						
Address	Function	Effective byte	Wind Direction	Check Code	Check Code	
0x02	0x03	0x02	0x00 0x8A	Low Order 0xFD	High Order 0xA0	

Wind Direction:

008A H(Hexadecimal)=138=> Wind direction = South-southeast

3.4.2. Device Output Value Corresponds To Wind Direction

Position

RS485 output data definition

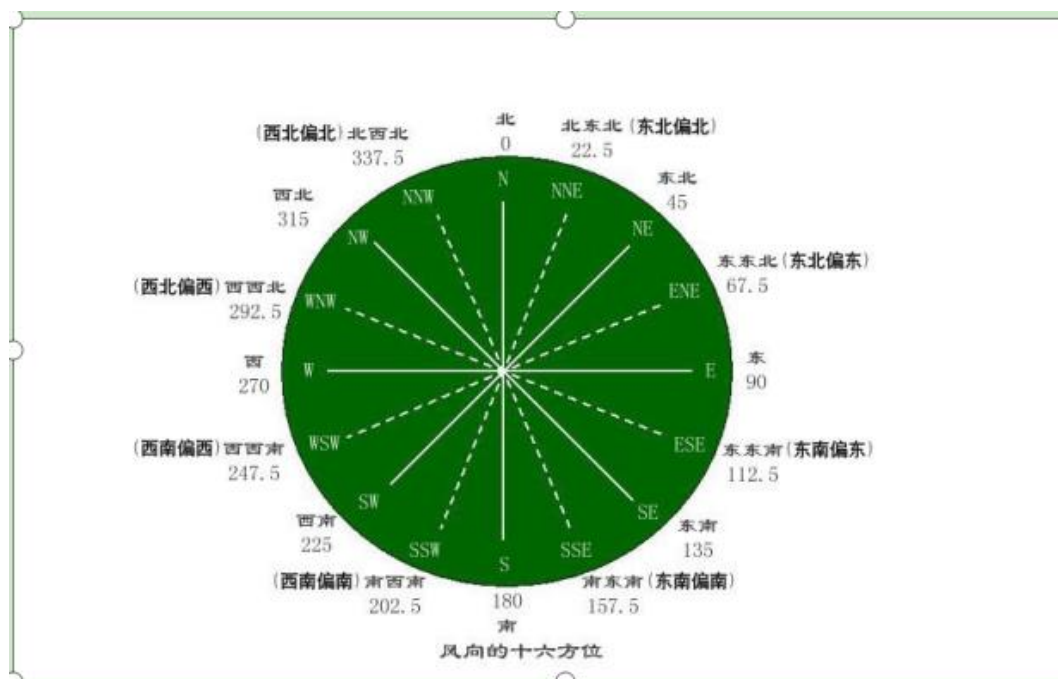

3.5. Notification

Please check whether the package is intact, and check whether the model and specification of the transmitter are consistent with the products you choose and buy; If you have any questions, please contact us as soon as possible.

Please confirm before use: power supply output voltage is correct; Positive and negative connection of power supply and product; And read the product manual in detail or consult our company. Any wrong wiring will cause irreversible damage to the transmitter.